

## Kundenstopper Swingmaster PREMIUM



### Customer stopper Swingmaster

The next generation in pavement signage. Excellent stability with a water or sand filled plastic base. Easy to move with integrated wheels to the base. Health and Safety design with no sharp edges. Snap frame closing to the vertical sides.

### Kundenstopper Swingmaster

Plakatständer für den Außeneinsatz. Idealer Hinweisträger in der Fußgängerzone. Stabil selbst bei sehr starkem Wind. Durch integrierte Rollen an der Unterseite leicht zu transportieren. Keine scharfen Ecken und Kanten.

# Kundenstopper Swingmaster PREMIUM

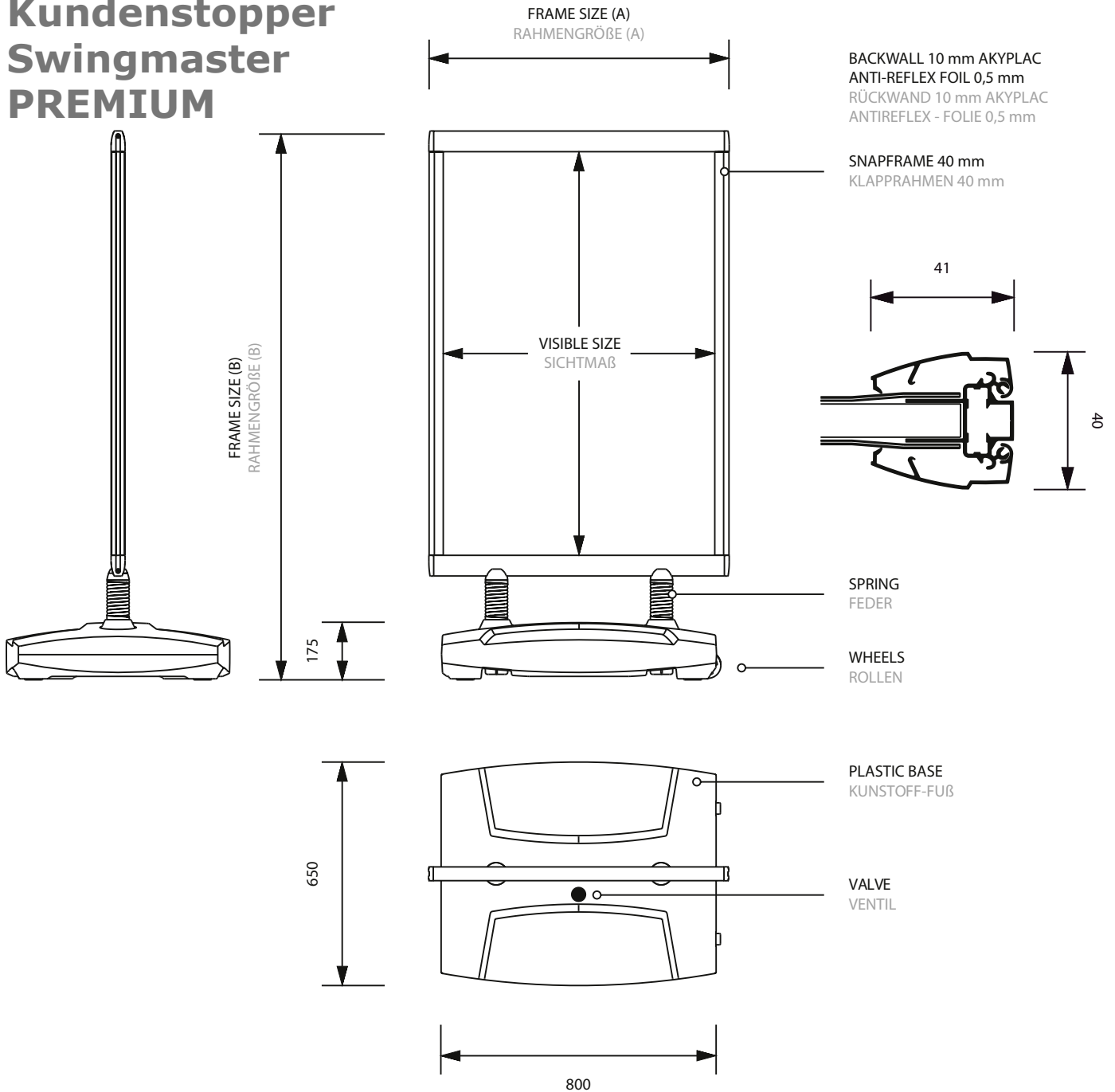

POSTER SIZE	VISIBLE SIZE	FRAME SIZE (A x B x C)	WEIGHT NETTO	PACKING SIZE	PACKING WEIGHT
PLAKATFORMAT	SICHTMAß	RAHMENGRÖßE (A x B x C)	NETTO GEWICHT	PACKUNG-GRÖßE	PACKUNGS-GEWICHT
594 x 841 mm (A1)	543 x 826 mm	812 x 1248 x 650 mm	15,38 kg	694 x 976 x 80 mm 940 x 670 x 200 mm	17,49 kg
841 x 1189 mm (A0)	790 x 1174 mm	874 x 1596 x 650 mm	23,65 kg	941 x 1324 x 80 mm 940 x 670 x 200 mm	26,77 kg
700 x 1000 mm	649 x 985 mm	812 x 1407 x 650 mm	21,37 kg	800 x 1135 x 80 mm 940 x 670 x 200 mm	23,89 kg